



## Unicable II™ Programmable/cascadable multiswitch with 32 User Bands, 4 Universal/Wideband Satellite inputs & 1 Terrestrial input

(AC/DC power adapter and power inserter)

Model: IDLU-UWT110-CUO10-32P

Item: 5294



The IDLU-UWT110-CUO10-32P is a small form factor Unicable II™ multiswitch enabling installations with up to 32 satellite receivers over a single cable based on digital channel stacking technology. Digital channel stacking technology applies digital signal processing after wideband Analog to Digital converters (full band capture) to select and reorder transponder channels.

The multiswitch supports both Dynamic and Static modes. In Dynamic mode (default), up to 32 EN50607-compatible receivers (or up to 16 EN50494-compatible) connected over the Unicable output ports, can select their desired transponder and receive it over the respective User Band. In Static mode, the multiswitch outputs a fixed transponder-to-IF frequency mapping and can line up to 32 transponders (depending on the bandwidth of the desired transponders) over its Unicable output ports. This allows for an unlimited number of receivers to be connected to the switch making MDU installations substantially cheaper and simpler than ever before.

This multiswitch has 4 satellite inputs that can receive (and cascade) either 4 universal satellite IF bands (LV, LH, HV and HH) from one satellite feed, or 2 wideband satellite IF signals (Horizontal and Vertical) from two satellite feeds. A unique feature of the multiswitch firmware allows to daisy chain two units and combine their outputs with external combiner to support connection of up to 4 wideband satellite IF signals from up to four satellite feeds. It also has a Terrestrial VHF/UHF input. The terrestrial signals are combined over both output ports of the multiswitch. The Terrestrial signal is not amplified.

The multiswitch has two outputs - by default, one of the ports is configured to function as a Unicable port in dynamic mode and the second is configured to function as Universal (Legacy) and switches to Unicable as soon as it receives an EN50494 or EN50607 command. The operating mode and configuration of each output port - unicable/universal, dynamic/static - output power level, channel bandwidth, UB numbers and protocol, center frequencies and the functionality of each of the output ports are fully programmable through Inverto's Unicable II™ Programmer device and PC software tool.

The multiswitch is powered over the supplied AC/DC adapter and power inserter device allowing greater flexibility in various installation scenarios. The communication protocol between the multiswitch unit and the connected receivers is based on EN50494 and/or EN50607 and can be defined per User Band allowing operators to support installations consisting of both EN50494-only and EN50607-compatible Next Generation PVRs and HGWs.

### Optional accessories (sold separately):

- Equipment for programming the multiswitch
 

5415 SatPal™ Controller	IDLU-SPAL03-OOBT-OPP
5393 Unicable II™ programmer	IDLU-PROG02-OOOO-OPN

For Indoor and outdoor installations (IP54)

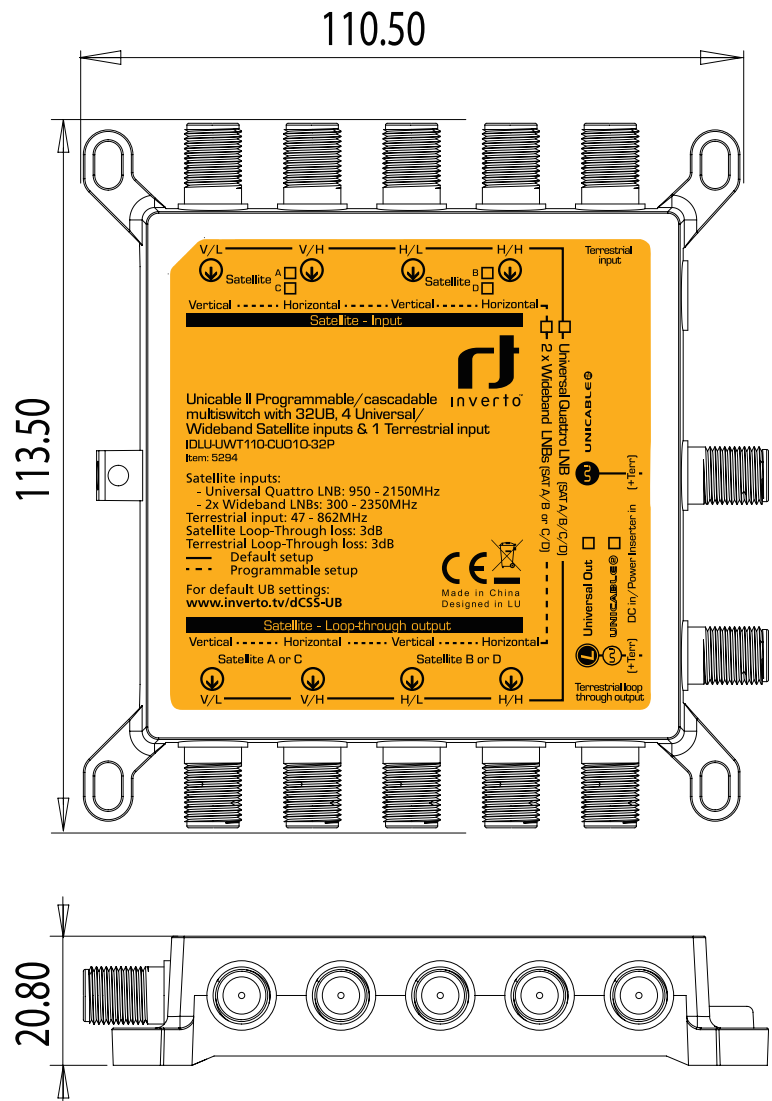
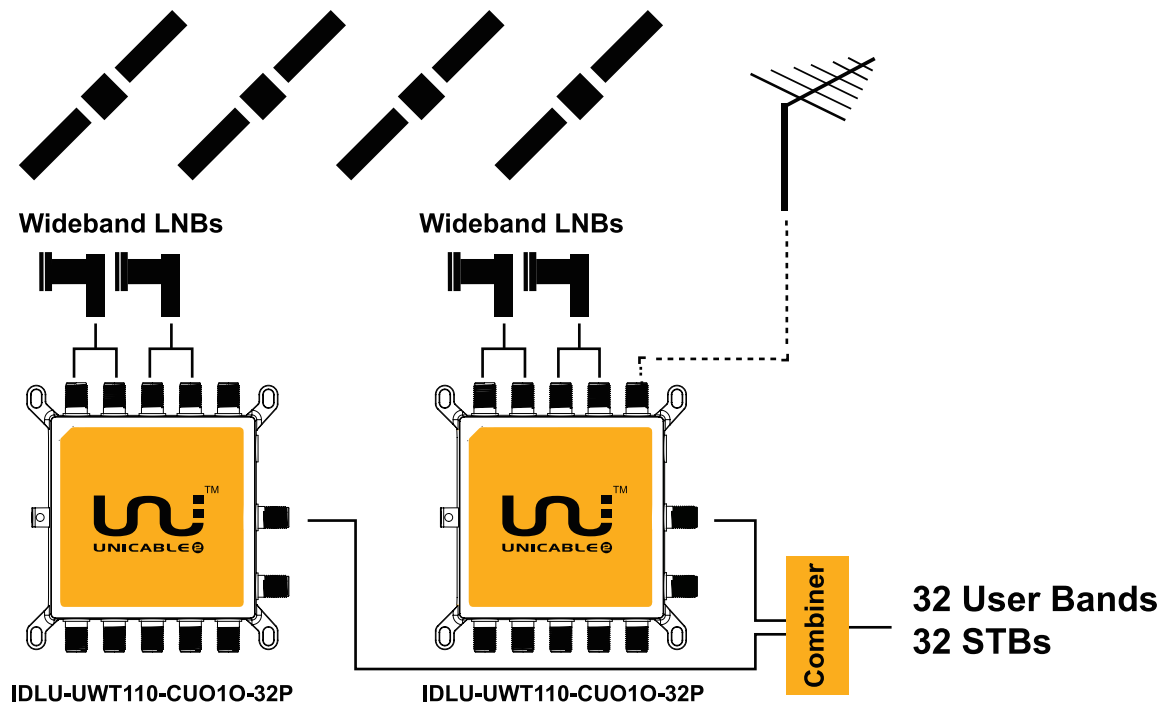

## 32 User Band Unicable multiswitch with Legacy port Connection Diagram

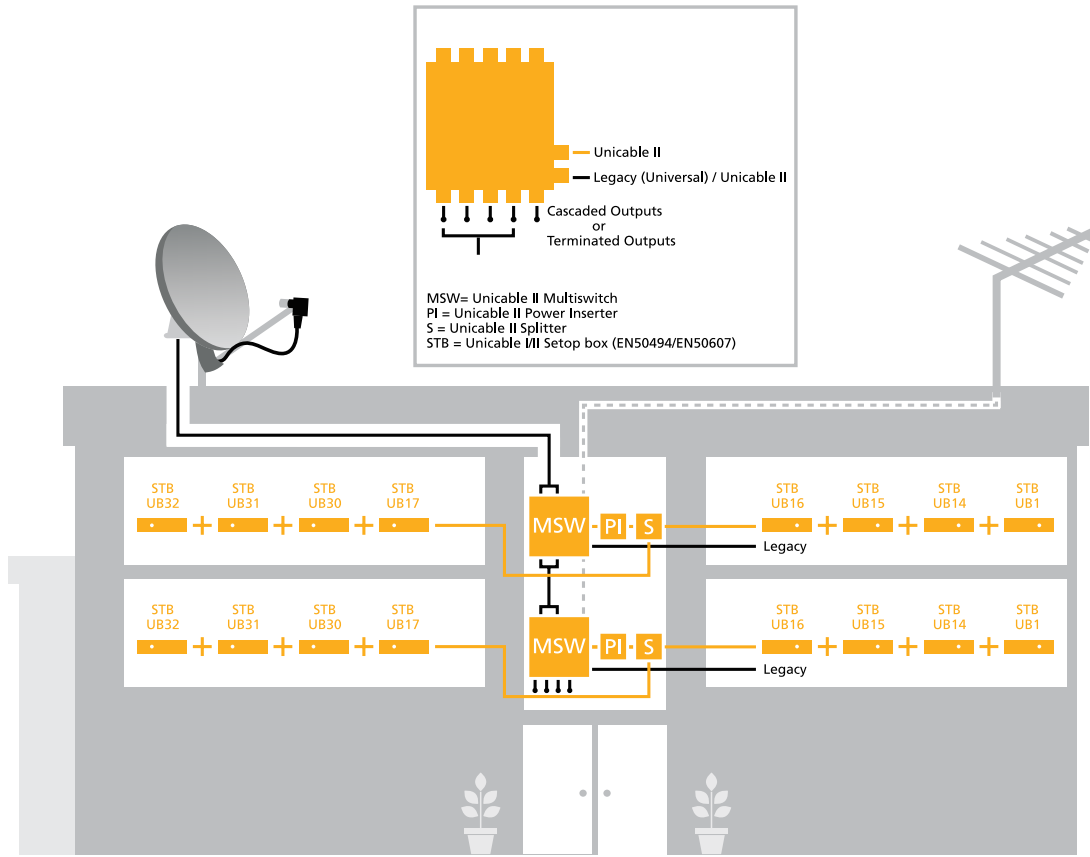

Supplied with AC/DC power adapter and power inserter

## Reception of two and four satellites through wideband LNBS

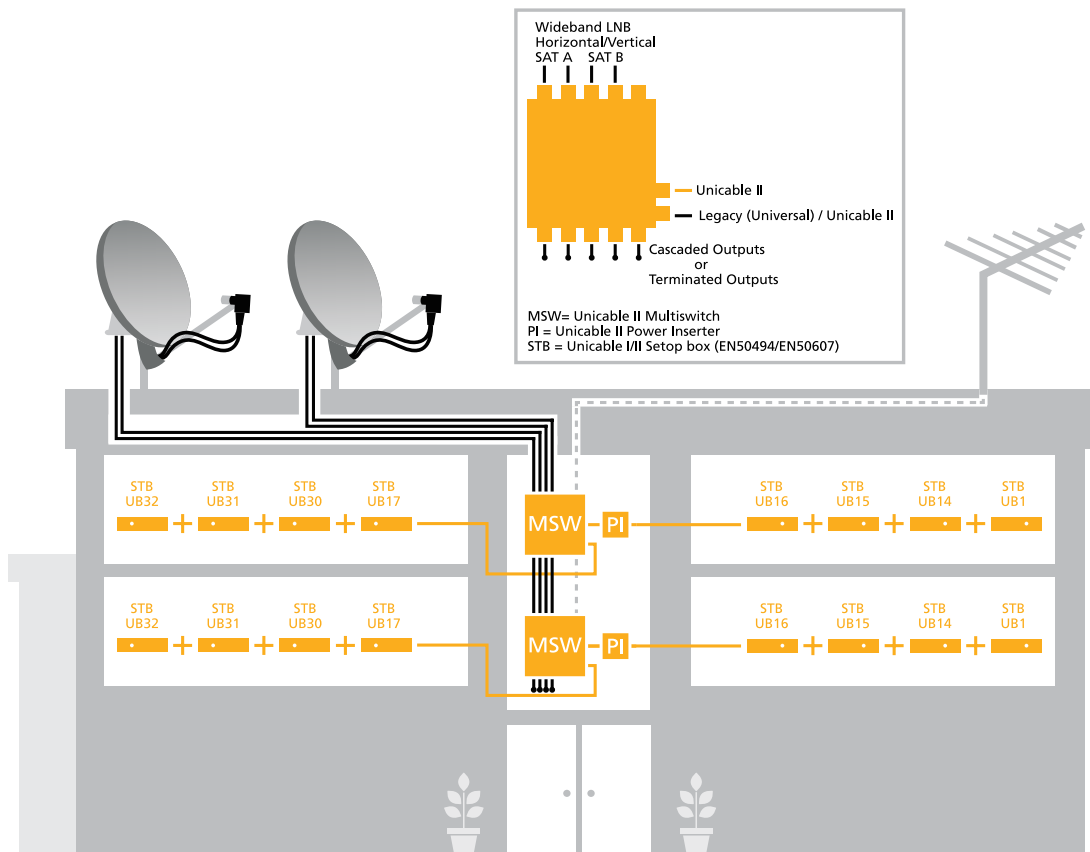

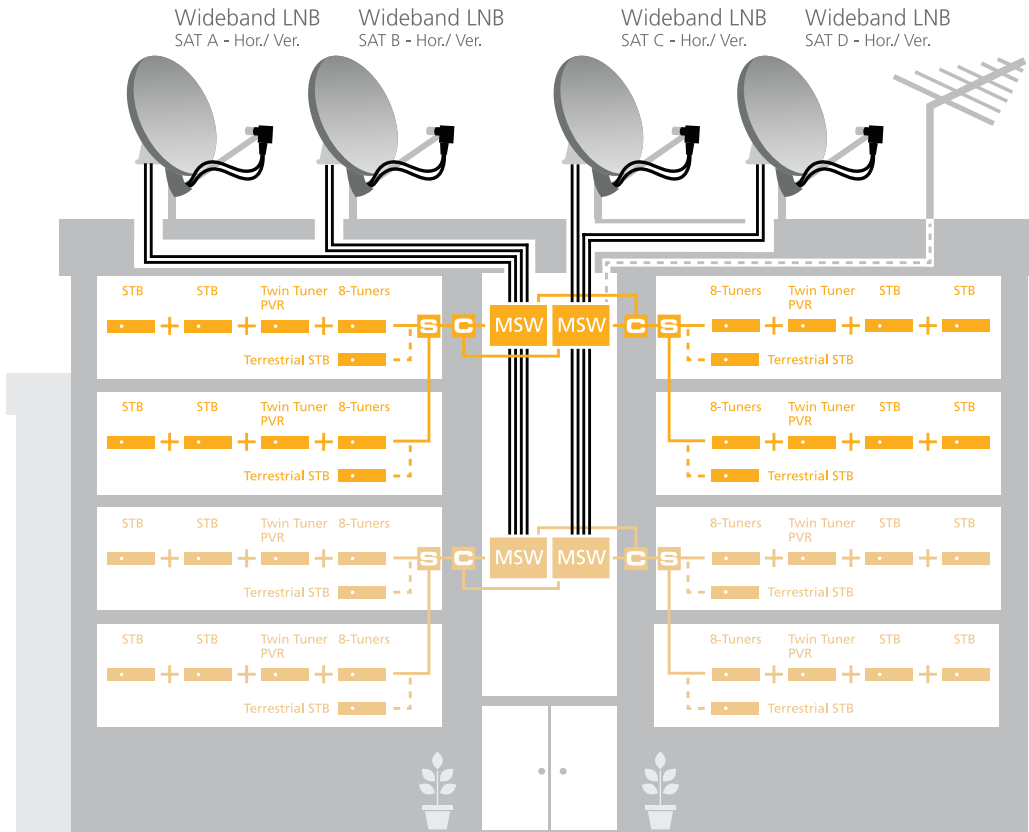

### Reception of a single satellite feed by up to 16 Unicable (EN50494) receivers

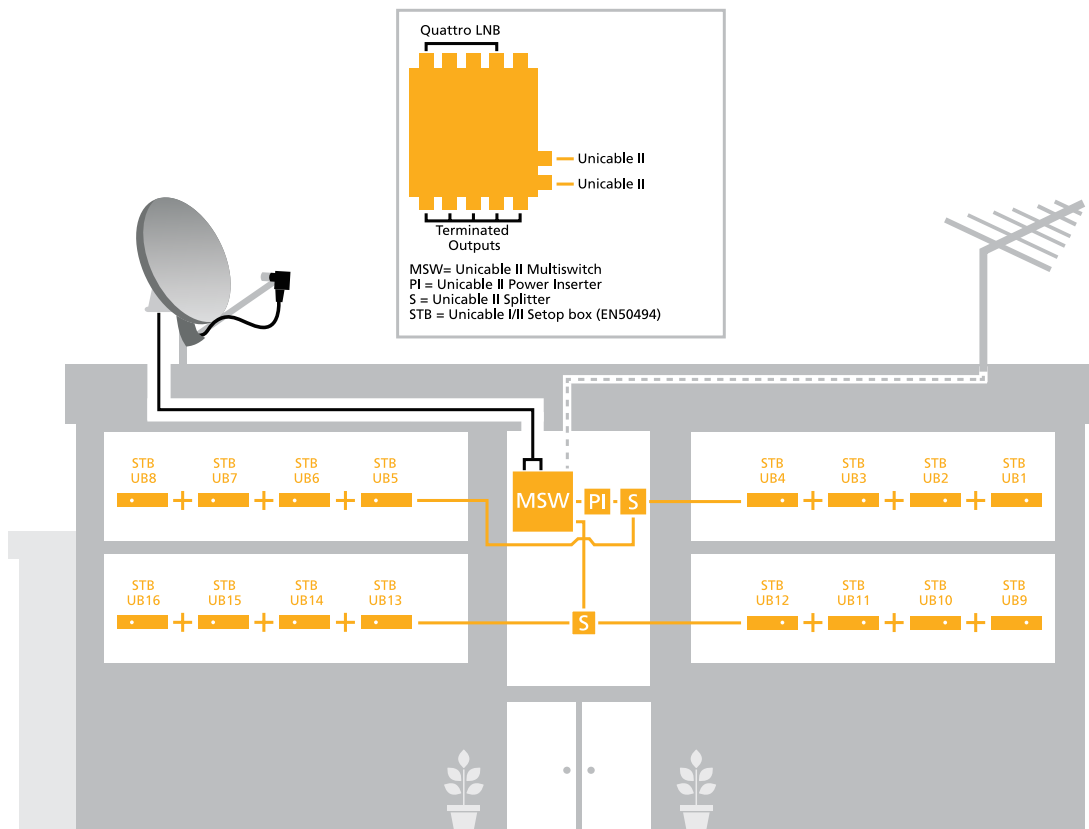

## Technical Specifications

Frequency range: satellite  
Frequency range: terrestrial

Inputs

Outputs

Input/Output impedance

Input power range

Output signal level (AGC)

RF isolation: satellite/satellite (input)

RF isolation: satellite/terrestrial (input)

RF isolation: satellite ch/ch (UBs, output)

Loop-through loss: satellite

Loop-through loss: terrestrial

LO phase noise @ 1 kHz

LO phase noise @ 10 kHz

LO phase noise @ 100 kHz

LO phase noise @ 1 MHz

Integrated phase noise

Output signal level (AGC)

Gain: Unicable II™ (dCSS) output (out of AGC)

Gain: legacy (universal) output

Control protocols

Legacy port switching

LNB power supply

Power consumption

Working temperature

IP protection

Product dimensions (H x W x D)

Weight

4 x IF inputs:

Quattro LNB: 950 MHz ~ 2150 MHz (default)

Wideband LNB: 300 MHz ~ 2350 MHz

47 MHz ~ 862 MHz

4x IF inputs:

- for 1x Quattro LNB (default)

- or 2x Wideband LNBs

1x UHF/VHF input for terrestrial antenna

4x Loophrough satellite IF outputs

1x Loophrough terrestrial output

1x Unicable II (dCSS/EN50607) output, dynamic (default) or static mode, supporting up to 32 UBs. With combined terrestrial signal.

1x Universal (Legacy) by default upon power up, auto switch to Unicable II™ upon receiving EN50494/EN50607 command. With combined terrestrial signal

75 Ω (F-type)

-50 dBm ~ -15dBm

2.5 : 1

25 dB min.

25 dB min.

28 dB min.

3 dB max.

3 dB max.

-80 dBc/Hz max.

-92 dBc/Hz max.

-96 dBc/Hz max.

-104 dBc/Hz max.

1.5° max.

Configurable (default -25 dBm)

25 dB min.

10 dB min.

DiSEqC 1.x/DiSEqC 2.0, EN50494/EN50607

V/L => 13 V/0 kHz, V/H => 13 V/22 kHz

H/L => 18 V/0 kHz, H/H => 18 V/22 kHz

300 mA max. @ 13 VDC ~ 18 VDC

500 mA @ 13 VDC max.

-20 °C ~ +60 °C

IP54

11.35 cm x 11.05 cm x 20.8 cm

165 g

### Unicable II™ (dCSS) port specifications

User band (channel) bandwidth

User band (channel) gain ripple

User band (channel) frequencies

Configurable, 10 MHz ~ 80 MHz (default 30MHz)

3 dB max.

Configurable; Default 32 User bands:

CH1: 1210MHz (EN50494+EN50607) CH17: 1530MHz (EN50607)

CH2: 1420MHz (EN50494+EN50607) CH19: 1602MHz (EN50607)

CH3: 1680MHz (EN50494+EN50607) CH20: 1638MHz (EN50607)

CH4: 2040MHz (EN50494+EN50607) CH21: 1716MHz (EN50607)

CH5: 984MHz (EN50494+EN50607) CH22: 1752MHz (EN50607)

CH6: 1020MHz (EN50494+EN50607) CH23: 1788MHz (EN50607)

CH7: 1056MHz (EN50494+EN50607) CH24: 1824MHz (EN50607)

CH8: 1092MHz (EN50494+EN50607) CH25: 1860MHz (EN50607)

CH9: 1128MHz (EN50607) CH26: 1896MHz (EN50607)

CH10: 1164MHz (EN50607) CH27: 1932MHz (EN50607)

CH11: 1256MHz (EN50607) CH28: 1968MHz (EN50607)

CH12: 1292MHz (EN50607) CH29: 2004MHz (EN50607)

CH13: 1328MHz (EN50607) CH30: 2076MHz (EN50607)

CH14: 1364MHz (EN50607) CH31: 2112MHz (EN50607)

CH15: 1458MHz (EN50607) CH32: 2148MHz (EN50607)

\* Unused ports need to be terminated by 75 Ohm DC-blocked terminators

For purpose of brevity, some product descriptions in this sheet remain at platform level and may not be referred to as detailed datasheets of the products. Inverto Digital Labs reserves the right to amend, omit or add products, product-lines, and / or features without notice. As product specifications may change without notice, always contact Inverto to obtain the latest product specification sheets.

For further details contact: [sales@inverto.tv](mailto:sales@inverto.tv)

FTA Communication Technologies S.à r.l. Tel. +352 264 367 1 Fax. +352 264 313 68



www.inverto.tv